

Approximative mass : 7 kg
Masse approximative

A-A

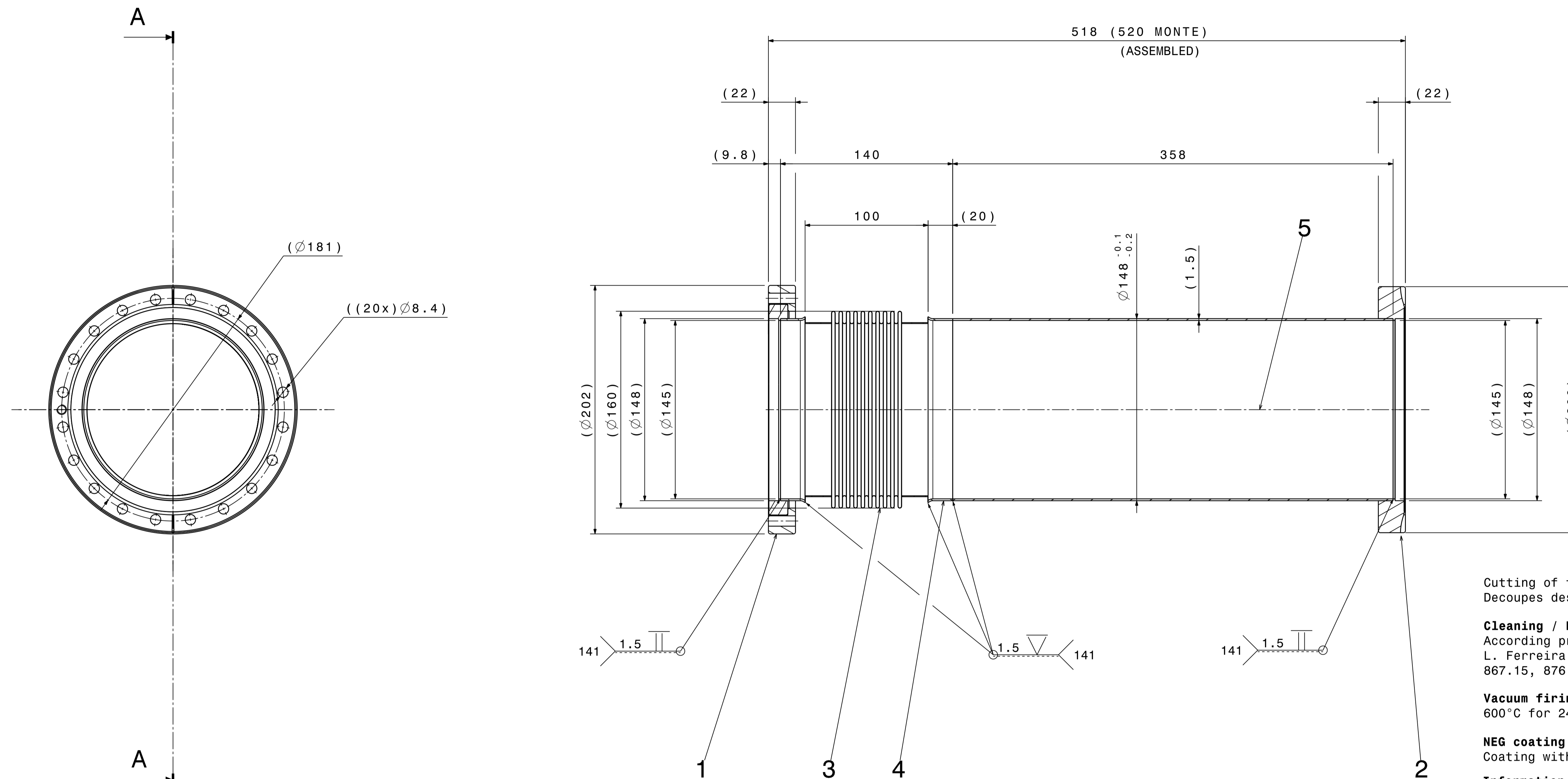

Cutting of the material : Ra 3.2/
Decoupes des matieres

Cleaning / Nettoyage
According procedure / Suivant procedures de
L. Ferreira, CERN Reports : Procedure Qualite 867.11,
867.15, 876.16 (2003)

Vacuum firing / Traitement Thermique
600°C for 24H / 600°C pendant 24H

NEG coating / Depot NEG
Coating with 2 μm Ti-Zr-V / Dépôt de 2 μm de Ti-Zr-V

Information
Inscribe drawing number on shades area
with an electrical pen
Inscrire le numero de detail sur une zone predefini
avec un stylo electrique

TOLERANCES DIMENSIONNELLES GÉNÉRALES	Tolerances geometriques, lineaires et angulaires	ISO 2768-mK-E
ARÊTES NON DÉFINIES	Arêtes de forme non définies	ISO 13715 $\sqrt{0.3}$ $\sqrt{0.3}$

✓ Ra 3.2/
($\sqrt{0.3}$)

1	SHEET TH. 1.5mm	5	ST. STEEL	Ø148/Ø145 LENGTH 362	44.59.32
	TOLE EP. 1.5mm		316LN	Ø148/Ø145 LONG. 362	015.3
2	TRANSITION PART Ø151/Ø148	4	ST. STEEL	E43.1018 DET.13	
	PIECE DE TRANSITION Ø151/Ø148		AC. INOX		
1	BELLOWS Ø160/Ø140 LENGTH 100	3	ST. STEEL	CALORSTAT SH.28.01691	
	SOUFFLET Ø160/Ø140 LONG. 100		AC. INOX		
1	UHV FIXED FLANGE Ø200/Ø148	2	ST. STEEL	E43.1033 DET.5	
	BRIDE UHV FIXE Ø200/Ø148		AC. INOX		
1	UHV ROTATIVE FLANGE Ø202/Ø148	1	ST. STEEL	E43.1034 DET.4	
	BRIDE UHV ROTATIVE Ø202/Ø148		AC. INOX		
QUANT.	DESCRIPTION	POS.	MAT.	OBSERVATIONS	REF. CERN
ENS/ASS	S.ENS/S.ASS				

LEI Vacuum Chamber for Transition Circular shape 145/148 (Variant G)		ECHELLE SCALE	DES/DRA.	ACROTECNA	2006-06-09
VACUUM CHAMBER ASSEMBLY CHAMBRE A VIDE ENSEMBLE		1:2	CONTROLLED		
			RELEASED		
			APPROVED		
			LEI \ VCTCGO \ LEIVCTCG0001		
			REPLACE / REMPLACES		

NON VALABLE POUR EXECUTION NOT VALID FOR EXECUTION	GAC	-	LEIVCTCG0001	SIZE	IND.
			1		

This drawing represents a part (or a component) of the vacuum system for LEIR with will operate at 10-10 Pa (10-12Torr). All welds must be made using the specified technics with 100% penetration. Welds and all other surfaces must not be finished by grinding or any other mechanical abrasion. Any part (or component) of the vacuum system showing a room temperature leak rate (localized or global), when measured with a calibrated UHV leak detector, in excess of 1x10⁻¹¹ Pa m³ s⁻¹ (7.5x10⁻¹¹ Torr ls⁻¹) will be considered as unacceptable.

Ce dessin represente une partie (ou composant) du systeme a vide LEIR qui fonctionnera a 10-10 Pa (10-12 Torr). Toutes les soudures seront realisees selon le procede specifique avec penetration de 100%. Ces soudures ne doivent etre ni meulees ni abrasees. Toute partie (ou composant) du systeme a vide ayant un taux de fuite (local ou global), qui est mesure a l'aide d'un detecteur de fuite UHV, superieur a 1x10⁻¹¹ Pa m³ s⁻¹ (7.5x10⁻¹¹ Torr ls⁻¹) sera considere comme inacceptable.

DRESSIN, RUGOSITE, TOLERANCES
 DRAWING, RUGOSITY, TOLERANCES
 ACCORDING TO ISO STANDARDS

ORGANIZATION RESPONSIBLE FOR
 EUROPEAN RESEARCH INFRASTRUCTURE
 EUROPEAN ORGANIZATION FOR NUCLEAR RESEARCH
 LEI VACUUM CHAMBER FOR TRANSITION CIRCULAR SHAPE 145/148 (Variant G)
 LEI VACUUM CHAMBER FOR TRANSITION CIRCULAR SHAPE 145/148 (Variant G)