

Approximative mass : 14 kg  
Masse approximative

A-A

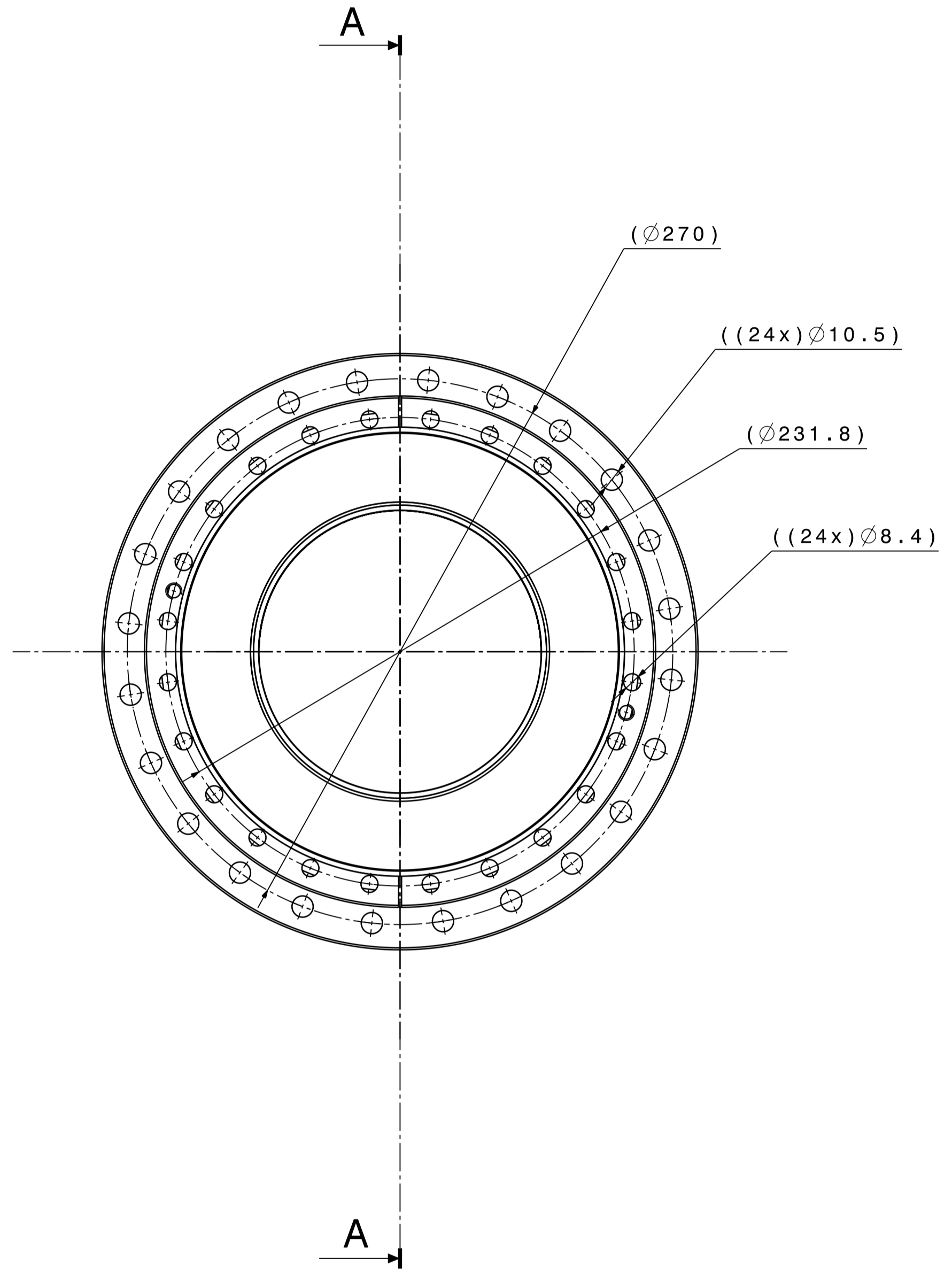
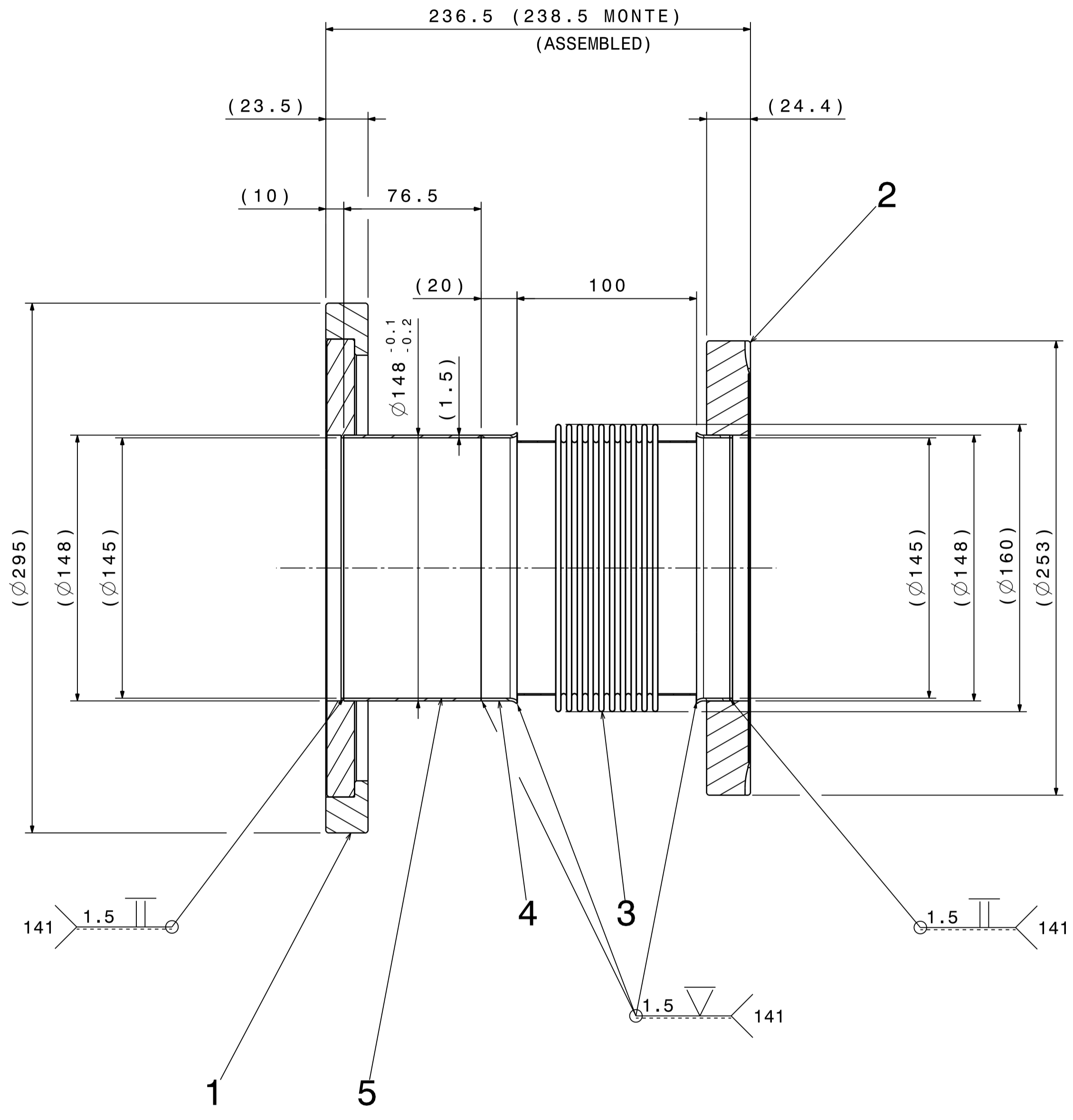

Cutting of the material : Ra 3.2  
Decoupees des matieres

**Cleaning / Nettoyage**  
According procedure / Suivant procedures de L. Ferreira, CERN Reports : Procedure Qualite 867.11, 867.15, 876.16 (2003)

**Vacuum firing / Traitement Thermique**  
600°C for 24H / 600°C pendant 24H

**NEG coating / Depot NEG**  
Coating with 2 µm Ti-Zr-V / Dépôt de 2 µm de Ti-Zr-V

**Information**  
Inscribe drawing number on shades area with an electrical pen  
Inscrire le numero de detail sur une zone predefini avec un stylo électrique

TOLERANCES DIMENSIONNELLES	Tolerances geometriques, lineaires et angulaires	ISO 2768-mK-E	Ra 3.2 ( $\nabla$ )
ARETES	Arêtes de forme non définies	ISO 13715 $\pm 0.3$ $\pm 0.3$	

1	SHEET TH. 1.5mm	5	ST. STEEL	Ø148/Ø145 LENGTH 80.5	44.59.32
	TOLE EP. 1.5mm		316LN	Ø148/Ø145 LONG. 80.5	015.3
2	TRANSITION PART Ø151/Ø148	4	ST. STEEL	E43.1018 DET.13	
	PIECE DE TRANSITION Ø151/Ø148		AC. INOX		
1	BELLOWS Ø160/Ø140 LENGTH 100	3	ST. STEEL	CALORSTAT SH.28.Ø1691	
	SOUFFLET Ø160/Ø140 LONG. 100		AC. INOX		
1	UHV FIXED FLANGE Ø253/Ø148	2	ST. STEEL	STDVUHV0059	
	BRIDE UHV FIXE Ø253/Ø148		AC. INOX		
1	UHV ROTATIVE FLANGE Ø295/Ø148	1	ST. STEEL	E43.1031	
	BRIDE UHV ROTATIVE Ø295/Ø148		AC. INOX		
QUANT.	DESCRIPTION	POS.	MAT.	OBSERVATIONS	REF. CERN
ENS/ASS	S. ENS/S. ASS				

LEI Vacuum Chamber for Transition Circular shape 145/148 (Variant 0)		ECHELLE SCALE	DES/DRA.	ACROTECNA	2006-06-28
VACUUM CHAMBER ASSEMBLY CHAMBRE A VIDE ENSEMBLE		1:2	CONTROLLED		
			RELEASED		
			APPROVED		
			LEI \ VCTCDO \ LEIVCTCDO001		
			REPLACE / REMPLACES		
NON VALABLE POUR EXECUTION NOT VALID FOR EXECUTION		GAC	LEIVCTCDO001	1	IND.

This drawing represents a part (or a component) of the vacuum system for LEIR with will operate at 10-10 Pa (10-12Torr). All welds must be made using the specified technics with 100% penetration. Welds and all other surfaces must not be finished by grinding or any other mechanical abrasion. Any part (or component) of the vacuum system showing a room temperature leak rate (localized or global), when measured with a calibrated UHV leak detector, in excess of 1x10<sup>-11</sup> Pa m<sup>3</sup> s<sup>-1</sup> (7.5x10<sup>-11</sup> Torr ls<sup>-1</sup>) will be considered as unacceptable.

Ce dessin represente une partie (ou composant) du systeme a vide LEIR qui fonctionnera a 10-10 Pa (10-12 Torr). Toutes les soudures seront realisees selon le procede specifique avec penetration de 100%. Ces soudures ne doivent etre ni meulees ni abrasees. Toute partie (ou composant) du systeme a vide ayant un taux de fuite (local ou global), qui est mesure a l'aide d'un detecteur de fuite UHV, superieur a 1x10<sup>-11</sup> Pa m<sup>3</sup> s<sup>-1</sup> (7.5x10<sup>-11</sup> Torr ls<sup>-1</sup>) sera considere comme inacceptable.

ORGANIZATION RESPONSIBLE FOR THE DESIGN, MANUFACTURE, TESTING, DELIVERY AND SUPPORT OF THE COMPONENTS OF THE VACUUM SYSTEM FOR LEIR  
 ORGANISATION RESPONSIBLE POUR LE DESSIN, LA FABRICATION, LES ESSAIS, LA LIVRAISON ET LE SUPPORT DES COMPOSANTS DU SYSTEME A VIDE POUR LEIR  
 EUROPEAN ORGANIZATION FOR NUCLEAR RESEARCH  
 ORGANISATION EUROPEENNE POUR LA RECHERCHE NUCLEAIRE  
 DRAWING, RUGOSITY, TOLERANCES ACCORDING TO ISO STANDARDS  
 DESSIN, RUGOSITE, TOLERANCES SELON NORMES ISO  
 PROJECTION